

DOOR HOLDER - Floor mounted DH504 SERIES

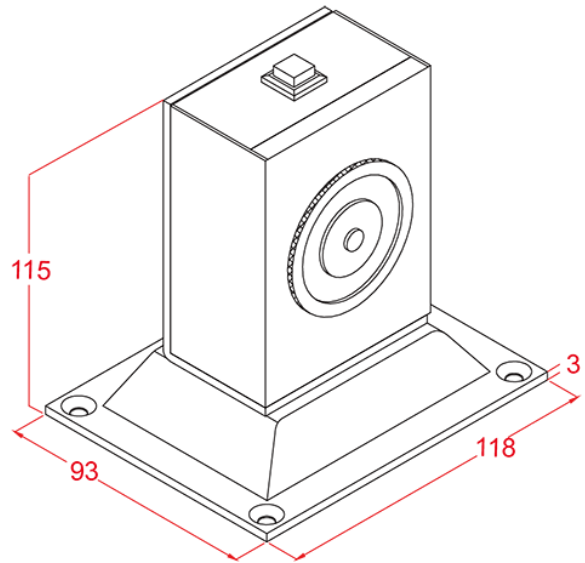

• DH504 : 118L*93W*115H mm



DOOR HOLDER

▼ ORDERING INFORMATION

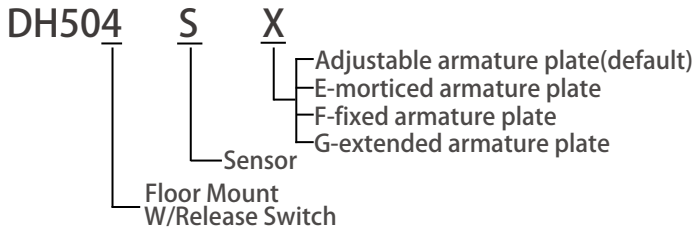

EXAMPLE :

- DH504 : Floor mounted, w/adjustable armature plate, w/release switch
- DH504S : Floor mounted, w/adjustable armature plate, w/release switch, monitored
- DH504F : Floor mounted, w/fixed armature plate, w/release switch

▼ SPECIFICATION

- Holding Force : about 100LBS
- Built-in voltage spike suppressor
- Sensor : optional
- Voltage : 12 / 24VDC (Selectable)
- Current Draw : 100mA / 12VDC ,
50mA / 24VDC

▼ FEATURES

- Suitable for fire escape doors in large-scale buildings.
- It releases the armature plate to allow the door closer to close the door when a fire alarm or emergency is detected, to keep smoke in a limited area.
- With Release Switch : to release the door for other purposes (e.g. function test)
- Adjustable, fixed, extended, or morticed armature plate

▼ ARMATURE PLATE INSTALLATION

- Adjustable Armature Plate (default) : applicable for environments with angle differences between the door and the wall

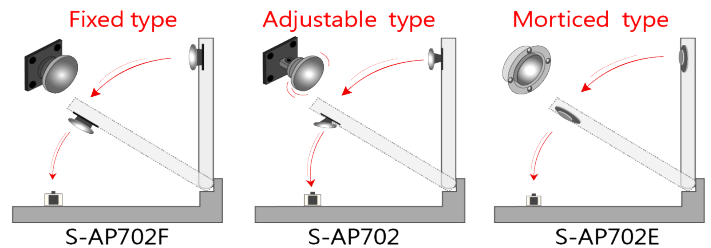

▼ APPLICATION

- Floor mount : applicable for installation environment with long distance between the door and the wall.

