

ELECTRIC STRIKES - ST1304 SERIES MONITORING

ELECTRIC STRIKES



ST1304SLD
(PATENTED)

- ST1304SLD : 175L*29W*26H mm

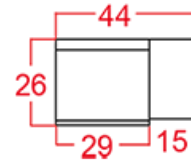
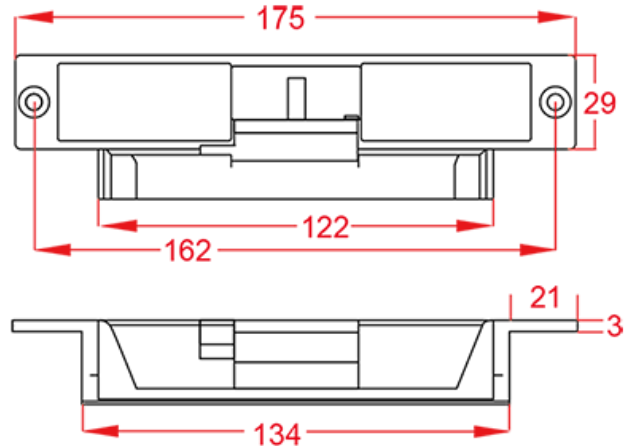

▼ ORDERING INFORMATION

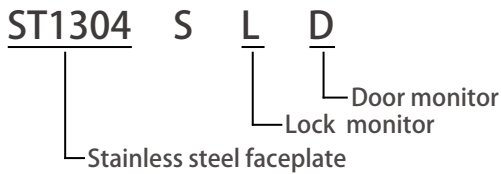

EXAMPLE :

- ST1304SL : Stainless steel faceplate fail secure W/Lock monitor
- ST1304SLD : Stainless steel faceplate fail secure W/door, lock monitor

▼ SPECIFICATION

- Stainless steel faceplate : 175L*29W*3T mm
- Door Latch : 1/2" (12.7mm)
- Keeper Depth : 10.8 mm
- Field selectable voltage input-
12 / 24VDC or 12 / 24VAC
280mA / 12VDC , 140mA / 24VDC
170mA / 12VAC , 85mA / 24VAC

▼ APPLICATION

